

CONTENTS

WORKSHOP MANUAL FOR TRACTOR
L3010/L3410/L3710/L4310/L4610

Part Number: 9789712191



CONTENTS

GENERAL

ENGINE

CLUTCH

TRANSMISSION

TRANSMISSION (HST)

REAR AXLE

BRAKES

FRONT AXLE

STEERING

HYDRAULIC SYSTEM

CONTENTS

ELECTRICAL SYSTEM

CABIN

MOWER

A L4610DT (SUPPLEMENT)

TO THE READER

This Workshop Manual has been prepared to provide servicing personnel with information on the mechanism, service and maintenance of KUBOTA Tractors L3010, L3410, L3710 and L4310. It is divided into two parts, "Mechanism" and "Servicing" for each section.

■ Mechanism

Information on the construction and function are included. This part should be understood before proceeding with troubleshooting, disassembling and servicing.

■ Servicing

Under the heading "General" section comes general precautions, check and maintenance and special tools. Other section, there are troubleshooting, servicing specification lists, checking and adjusting, disassembling and assembling, and servicing which cover procedures, precautions, factory specifications and allowable limits.

All information, illustrations and specifications contained in this manual are based on the latest production information available at the time of publication.

The right is reserved to make changes in all information at any time without notice.

June '98



SAFETY FIRST

This symbol, the industry's "Safety Alert Symbol", is used throughout this manual and decals on the machine itself to warn of the possibility of personal injury. Read these instructions carefully. It is essential that you read the instructions and safety regulations before you attempt to repair or use this unit.



DANGER : Indicates an imminently hazardous situation which, if not avoided, will result in death or serious injury.



WARNING : Indicates a potentially hazardous situation which, if not avoided, could result in death or serious injury.



CAUTION : Indicates a potentially hazardous situation which, if not avoided, may result in minor or moderate injury.



IMPORTANT : Indicates that equipment or property damage could result if instructions are not followed.



NOTE : Gives helpful information.

SAFETY SERVICING AND REPAIRING

- (1) Before working on the machine :
 - Park the machine on a firm and level ground, and set the parking brake.
 - Lower the implement or mower to the ground.
 - Stop the engine, and remove the key.
 - Disconnect the battery's ground cable.
 - Clean the work area and machine.
- (2) Do not work on the machine while under the influence of alcohol, medication, or other substances or while fatigued.
- (3) Do not wear a necktie, scarf, necklace, loose or bulky clothing when you work near machine tools or moving parts.
- (4) Use tools appropriate to the work. Makeshift tools, parts, and procedures will not make good repairs.
- (5) When servicing is performed together by two or more persons, take care to perform all work safely.
- (6) Do not work under the machine that is supported solely by a jack. Always support the machine by safety stands.

- (7) If the engine must be running to do same work, make sure the area is well ventilated. Never run the engine in a closed area. The exhaust gas contains poisonous carbon monoxide.
- (8) Do not touch the rotating or hot parts while the engine is running.
- (9) Fuel is extremely flammable and explosive under certain conditions. Do not smoke or allow flames or sparks in your working area.
- (10) To avoid sparks from an accidental short circuit, always disconnect the battery's ground cable first and connect it last.
- (11) Sulfuric acid in battery electrolyte is poisonous. It is strong enough to burn skin, clothing and cause blindness if splashed into eyes. Keep electrolyte away from eyes, hands and clothing. If you spill electrolyte on yourself, flush with water, and get medical attention immediately.
- (12) Battery gas can explode. Keep sparks and open flame away from the top of battery, especially when charging the battery.
- (13) Never remove the radiator cap while the engine is running, or immediately after stopping. Otherwise, hot water will spout out from radiator. Wait for more than ten minutes to cool the radiator, before removing the cap.
- (14) Escaping fluid (fuel or hydraulic oil) under pressure can penetrate the skin causing serious injury. Relieve pressure before disconnecting hydraulic or fuel lines. Tighten all connections before applying pressure.
- (15) Do not start the engine by shorting across starter terminals.
- (16) Unauthorized modifications to the machine may impair the function and / or safety and affect machine life.
- (17) Do not alter or remove any part of machine safety system.
- (18) Keep a first aid kit and fire extinguisher handy at all times.
- (19) Be sure to chock the wheels to prevent accident during servicing the machine.

SAFETY DECALS

- The following safety decals are installed on the machine.
If a decal becomes damaged, illegible or is not on the machine, replace it. The decal part number is listed in the parts list.

① Part No. TA040-4965-2





⚠ DANGER

TO AVOID POSSIBLE INJURY OR DEATH FROM A MACHINE RUNAWAY.

- Do not start engine by shorting across starter terminals or bypassing the safety start switch. Machine may start in gear and move if normal starting circuitry is bypassed.
- Start engine only from operator's seat with transmission and PTO OFF. Never start engine while standing on the ground.

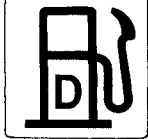
⑤ Part No. TA040-4956-2
Diesel fuel only No fire





② Part No. TA040-4932-2

⚠ WARNING

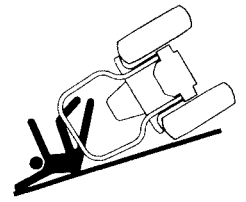

TO AVOID PERSONAL INJURY OR DEATH FROM ROLL-OVER:

- Kubota recommends the use of a Roll-Over Protective Structures (ROPS) and seat belt in almost all applications.
- Remove the ROPS only when it substantially interferes with operation or itself presents a safety risk. (Examples include work in orchards and vineyards.) ALWAYS REINSTALL IT BEFORE USING THE TRACTOR IN OTHER APPLICATIONS.
- Never use just the seat belt or just the ROPS. They must be used together. For further details, consult your Operator's Manual or your local dealer.

⑥ Part No. TA040-4934-1

⚠ WARNING

TO AVOID PERSONAL INJURY:
Do not operate rear-PTO driven implements and mid-PTO driven implements at the same time.

③ Part No. TA040-4959-3



⚠ WARNING

TO AVOID PERSONAL INJURY.

- Keep PTO shield in place at all times.
- Do not operate the PTO at speeds faster than the speed recommended by the implement manufacturer.
- For trailing PTO-driven implements, set drawbar at towing position. (see operator's manual)

⑦ Part No. TA040-4935-1

⚠ WARNING

TO AVOID PERSONAL INJURY:

- Attach pulled or towed loads to the drawbar only.
- Use the 3-point hitch only with equipment designed for 3-point hitch usage.

④ Part No. TA240-4991-1 [HST type]

⚠ WARNING

Do not start engine with speed set lever engaged or control pedal operated.

⑧ Part No. 35080-6528-2

⚠ CAUTION

Pull the engine stop knob back and hold it until the engine stops in case of emergency.

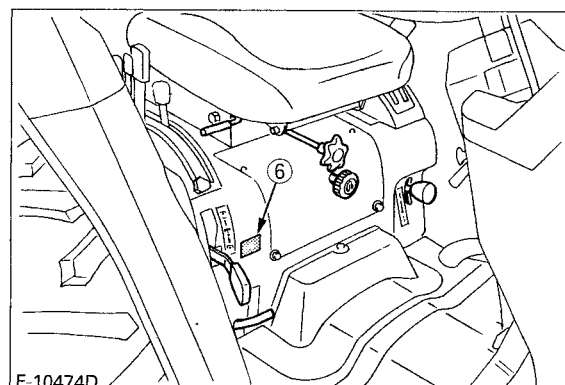
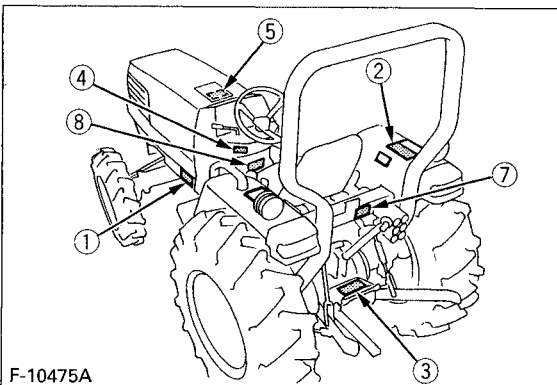

⑨Part No. TA140-4992-1 [GST type]

▲ WARNING

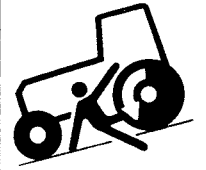

BEFORE DISMOUNTING TRACTOR:
1. ALWAYS SET PARKING BRAKE.
 Leaving transmission in gear with the engine stopped will not prevent tractor from rolling.
2. PARK ON LEVEL GROUND WHENEVER POSSIBLE.
 If parking on a slope, position tractor across the slope.
3. LOWER ALL IMPLEMENTS TO THE GROUND.
 Failure to comply to this warning may allow the wheels to slip, and could cause injury or death.
4. LOCK SHUTTLE SHIFT LEVER IN NEUTRAL POSITION AND STOP THE ENGINE.

⑨Part No. TA240-4933-2 [HST type]

▲ WARNING



BEFORE DISMOUNTING TRACTOR:
1. ALWAYS SET PARKING BRAKE.
 Leaving transmission in gear with the engine stopped will not prevent tractor from rolling.
2. PARK ON LEVEL GROUND WHENEVER POSSIBLE.
 If parking on a slope, position tractor across the slope.
3. LOWER ALL IMPLEMENTS TO THE GROUND.
 Failure to comply to this warning may allow the wheels to slip, and could cause injury or death.
4. STOP THE ENGINE.

⑨Part No. TA140-4933-1 [Manual Transmission type]

▲ WARNING



BEFORE DISMOUNTING TRACTOR:
1. ALWAYS SET PARKING BRAKE.
2. PARK ON LEVEL GROUND WHENEVER POSSIBLE.
 If parking on a slope, position tractor across the slope.
3. LOWER ALL IMPLEMENTS TO THE GROUND.
 Failure to comply to this warning may allow the wheels to slip, and could cause injury or death.
4. LOCK SHUTTLE SHIFT LEVER IN NEUTRAL POSITION AND STOP THE ENGINE.

⑩Part No. 35260-3491-3

▲ CAUTION

TO AVOID PERSONAL INJURY:

1. Read and understand the operator's manual before operation
2. Before starting the engine, make sure that everyone is at a safe distance from the tractor and that the PTO is OFF.
3. Do not allow passengers on the tractor at any time
4. Before allowing other people to use the tractor, have them read the operator's manual.
5. Check the tightness of all nuts and bolts regularly.
6. Keep all shields in place and stay away from all moving parts
7. Lock the two brake pedals together before driving on the road.
8. Slow down for turns, or rough roads, or when applying individual brakes.
9. On public roads use SMV emblem and hazard lights, if required by local traffic and safety regulations.
10. Pull only from the drawbar.
11. Before dismounting, lower the implement, set the parking brake, stop the engine and remove the key.

⑫Part No. TA040-4957-1
 Stay clear of engine fan and fanbelt.



⑬Part No. TA040-4958-1
 Do not touch hot surface like muffler, etc.



⑪Part No. TA040-3015-1

DANGER EXPLOSIVE GASES

Cigarettes, flames or sparks could cause battery to explode. Always shield eyes and face from battery. Do not charge or use booster cables or adjust post connections without proper instruction and training.

KEEP VENT CAPS TIGHT AND LEVEL

POISON CAUSES SEVERE BURNS

Contains sulfuric acid. Avoid contact with skin, eyes or clothing. In event of accident flush with water and call a physician immediately.

KEEP OUT OF REACH OF CHILDREN

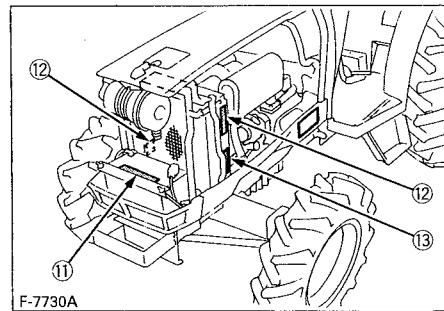
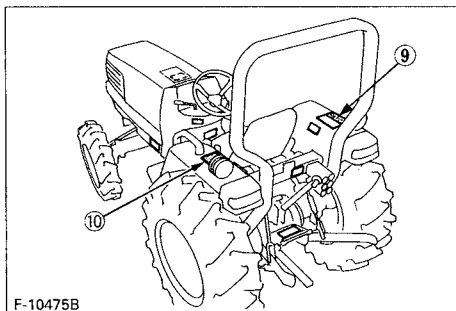

SPECIFICATIONS

Model		L3010			
		2WD	4WD	4WD-GST	4WD-HST
Maximum PTO power		19.1 kW (25.5 HP)*			17.9 kW (24.0 HP)*
Engine NET power		22.6 kW (30.4 HP)*			
Engine	Model	D1503-L-A			
	Type	Indirect injection, Vertical, Water-Cooled, 4-cycle diesel engine			
	Number of cylinders	3			
	Bore and stroke	83 x 92.4 mm (3.3 x 3.6 in.)			
	Total displacement	1499 cm ³ (91.5 cu.in.)			
	Rated revolution	45.0 r/s (2700 rpm)			
	Combustion chamber	Spherical type (E-TVCS)			
	Fuel injection pump	Bosch type mini pump (PFR3M)			
	Governor	Centrifugal ball mechanical governor			
	Injection nozzle	Throttle type			
	Injection timing	Before T.D.C. 0.314 rad (18°)			
	Injection order	1-2-3			
	Injection pressure	13.73 MPa (140 kgf/cm ² , 1991 psi)			
	Compression ratio	23 : 1			
	Lubricating system	Forced lubrication by trochoidal pump			
	Cooling system	Pressurized radiator, Forced circulation with water pump			
	Starting system	Electric starting with cell starter 12 V, 1.2 kW			
	Alternator	12 V, 480 W (40 AMPS)			
	Battery	12V, RC : 123 min, CCA : 490- Cold cranking Amps at -18 °C (-0.4 °F)			
	Fuel	Diesel fuel No. 1 [below - 10 °C (14 °F)] Diesel fuel No. 2 [above - 10 °C (14 °F)]			
Lubricating oil	CC or CD (API grade)				
Weight (Dry)	176 kg (388 lbs)				
Capacities	Fuel tank	35.0 ℓ (9.2 U.S.gals., 7.7 Imp.gals.)			
	Engine crankcase	5.5 ℓ (5.8 U.S.qts., 4.8 Imp.qts.)			
	Engine coolant	7.0 ℓ (7.4 U.S.qts., 6.2 Imp.qts.)			
	Transmission case	39.0 ℓ (10.3 U.S.gals., 8.6 Imp.gals.)			
	Front axle case	—	5.5 ℓ (5.8 U.S.qts., 4.8 Imp.qts.)		
Dimensions with Std. tires)	Overall length (without 3P)	2820 mm (111.0 in.)			
	Overall length (with 3P)	3060 mm (120.5 in.)			
	Overall width (minimum tread)	1325 mm (52.2 in.)			
	Overall height (Top of ROPS)	2090 mm (82.3 in.)			
	Overall height (Top of steering wheel)	1515 mm (59.6 in.)			
	Wheel base	1675 mm (65.9 in.)	1670 mm (65.7 in.)		
	Min. ground clearance (Under transmission)	325 mm (12.8 in.)			
	Tread	Front mm (in.)	960 (37.8), 1060 (41.7), 1160 (45.7), 1260 (49.6)	1105 (43.5)	
	Rear mm (in.)	1120 (44.1), 1220 (48.0), 1305 (51.4), 1405 (55.3)			

Note : * Manufacturer's estimate

Model			L3010				
			2WD	4WD	4WD-GST	4WD-HST	
Traveling system	Tire size (Std. tires)	Front	5.00 – 15	7.2 – 16			
		Rear	11.2 – 24				
	Clutch	Dry type single stage					
	Steering	Hydrostatic power steering					
	Transmission	Synchronized shuttle and synchronized transmission (8 forward and 8 reverse speeds)		Glide shift transmission 8 forward and 8 reverse speeds)		Hydrostatic transmission (3 speeds)	
	Brake	Traveling	Wet disc type				
		Parking	Connected with the traveling brake				
Differential	Bevel gear						
Hydraulic system	Hydraulic control system		Position control, Draft and Mixed control (if equipped)				
	Pump capacity (Max. flow rate)		Main pump 26.4 ℓ/min (7.0 GPM) Power steering pump 17.7 ℓ/min (4.7 GPM)				
	Three point hitch		SAE Category I				
	Maximum lifting capacity (24 in. behind lower link end)		1000 kg (2200 lbs)				
Rear PTO	PTO shaft		SAE 1–3/8, 6-splines (with overrunning clutch)				
	Revolution	Transmission PTO	1 speed : 9.0 r/s (540 rpm) / engine 44.5 r/s (2670 rpm)			—	
		Independent PTO	1 speed : 9.0 r/s (540 rpm) / engine 45.0 r/s (2700 rpm)			1 speed : 9.0 r/s (540 rpm) / engine 45.3 r/s (2713 rpm)	
Mid PTO	PTO shaft		USA No. 5 (KUBOTA 10-tooth) involute spline				
	Revolution	Transmission PTO	1 speed : 33.3 r/s (2000 rpm) / engine 43.7 r/s (2623 rpm)			—	
		Independent PTO	1 speed : 33.3 r/s (2000 rpm) / engine 44.2 r/s (2653 rpm)			1 speed : 33.3 r/s (2000 rpm) / engine 44.4 r/s (2666 rpm)	
Min. turning radius (with brake)			2.4 m (7.9 ft)	2.3 m (7.5 ft)	2.5 m (8.2 ft)		
Traction system			Fixed drawbar or swing drawbar (if equipped)				
Weight (with ROPS)			1160 kg (2560 lbs)	1230 kg (2710 lbs)	1235 kg (2720 lbs)	1245 kg (2745 lbs)	
Traveling speed (at rated engine speed with Std. tires)	Forward	1st	1.5 km/h (0.9 mph)			Low : 0 to 6.6 km/h (0 to 4.1 mph)	
		2nd	2.1 km/h (1.3 mph)				
		3rd	3.5 km/h (2.2 mph)			Middle : 0 to 12.4 km/h (0 to 7.7 mph)	
		4th	5.1 km/h (3.2 mph)				
		5th	7.3 km/h (4.5 mph)			High : 0 to 26.4 km/h (0 to 16.4 mph)	
		6th	10.3 km/h (6.4 mph)				
		7th	16.7 km/h (10.4 mph)				
		8th	24.7 km/h (15.3 mph)				
	Reverse	1st	1.4 km/h (0.8 mph)			Low : 0 to 6.6 km/h (0 to 4.1 mph)	
		2nd	2.0 km/h (1.2 mph)				
		3rd	3.2 km/h (2.0 mph)			Middle : 0 to 12.4 km/h (0 to 7.7 mph)	
		4th	4.7 km/h (2.9 mph)				
		5th	6.7 km/h (4.2 mph)			High : 0 to 21.1 km/h (0 to 13.1 mph)	
		6th	9.5 km/h (5.9 mph)				
		7th	15.3 km/h (9.5 mph)				
8th		22.7 km/h (14.1 mph)					

SPECIFICATIONS (Continued)

Model		L3410		
		4WD	4WD-GST	4WD-HST
Maximum PTO power		21.3 kW (28.5 HP)*		20.1 kW (27.0 HP)*
Engine NET power		24.9 kW (33.3 HP)*		
Engine	Model	D1703- A		
	Type	Indirect injection, Vertical, Water-Cooled, 4-cycle diesel engine		
	Number of cylinders	3		
	Bore and stroke	87 x 92.4 mm (3.4 x 3.6 in.)		
	Total displacement	1647 cm ³ (100.5 cu.in.)		
	Rated revolution	45.0 r/s (2700 rpm)		
	Combustion chamber	Spherical type (E-TVCS)		
	Fuel injection pump	Bosch type mini pump (PFR3M)		
	Governor	Centrifugal ball mechanical governor		
	Injection nozzle	Throttle type		
	Injection timing	Before T.D.C. 0.314 rad (18°)		
	Injection order	1-2-3		
	Injection pressure	13.73 MPa (140 kgf/cm ² , 1991 psi)		
	Compression ratio	23 : 1		
	Lubricating system	Forced lubrication by trochoidal pump		
	Cooling system	Pressurized radiator, Forced circulation with water pump		
	Starting system	Electric starting with cell starter 12 V, 1.2 kW		
	Alternator	12 V, 480 W (40 AMPS)		
	Battery	12V, RC : 123 min, CCA : 490- Cold cranking Amps at -18 °C (- 0.4 °F)		
	Fuel	Diesel fuel No. 1 [below - 10 °C (14 °F)] Diesel fuel No. 2 [above - 10 °C (14 °F)]		
Lubricating oil	CC or CD (API grade)			
Weight (Dry)	176 kg (388 lbs)			
Capacities	Fuel tank	35.0 ℓ (9.2 U.S.gals., 7.7 Imp.gals.)		
	Engine crankcase	5.5 ℓ (5.8 U.S.qts., 4.8 Imp.qts.)		
	Engine coolant	7.0 ℓ (7.4 U.S.qts., 6.2 Imp.qts.)		
	Transmission case	39.0 ℓ (10.3 U.S.gals., 8.6 Imp.gals.)		
	Front axle case	—	5.5 ℓ (5.8 U.S.qts., 4.8 Imp.qts.)	
Dimensions (with Std. tires)	Overall length (without 3P)	2850 mm (112.2 in.)		
	Overall length (with 3P)	3060 mm (120.5 in.)		
	Overall width (minimum tread)	1355 mm (53.5 in.)		
	Overall height (Top of ROPS)	2130 mm (83.9 in.)		
	Overall height (Top of steering wheel)	1530 mm (60.2 in.)		
	Wheel base	1670 mm (65.7 in.)		
	Min. ground clearance (Under transmission)	350 mm (13.8 in.)		
	Tread	Front mm (in.)	1105 (43.5)	
Rear mm (in.)		1120 (44.1), 1220 (48.0), 1305 (51.4), 1405 (55.3)		

Note : * Manufacturer's estimate

Model			L3410			
			4WD	4WD-GST	4WD-HST	
Traveling system	Tire size (Std. tires)	Front	7 – 16		7.2 – 16	
		Rear	12.4 – 24			
	Clutch	Dry type single stage				
	Steering	Hydrostatic power steering				
	Transmission	Synchronized shuttle and synchronized transmission (8 forward and 8 reverse speeds)	Glide shift transmission (8 forward and 8 reverse speeds)	Hydrostatic transmission (3 speeds)		
	Brake	Traveling	Wet disc type			
		Parking	Connected with the traveling brake			
Differential	Bevel gear					
Hydraulic system	Hydraulic control system		Position control, Draft and Mixed control (if equipped)			
	Pump capacity (Max. flow rate)		Main pump 26.4 ℓ/min (7.0 GPM) Power steering pump 17.7 ℓ/min (4.7 GPM)			
	Three point hitch		SAE Category I			
	Maximum lifting capacity (24 in. behind lower link end)		1000 kg (2200 lbs)			
Rear PTO	PTO shaft		SAE 1-3/8, 6-splines (with overrunning clutch)			
	Revolution	Transmission PTO	1 speed : 9.0 r/s (540 rpm) /engine 44.5 r/s (2670 rpm)		—	
		Independent PTO	1 speed : 9.0 r/s (540 rpm) /engine 45.0 r/s (2700 rpm)		1 speed : 9.0 r/s (540 rpm) / engine 45.3 r/s (2713 rpm)	
Mid PTO	PTO shaft		USA No. 5 (KUBOTA 10-tooth) involute spline			
	Revolution	Transmission PTO	1 speed : 33.3 r/s (2000 rpm) / engine 43.7 r/s (2623 rpm)		—	
		Independent PTO	1 speed : 33.3 r/s (2000 rpm) / engine 44.2 r/s (2653 rpm)		1 speed : 33.3 r/s (2000 rpm) / engine 44.4 r/s (2666 rpm)	
Min. turning radius (with brake)		2.3 m (7.6 ft)	2.5 m (8.2 ft)			
Traction system		Fixed drawbar or swing drawbar (if equipped)				
Weight (with ROPS)		1255 kg (2765 lbs)	1260 kg (2780 lbs)	1270 kg (2800 lbs)		
Traveling speed (at rated engine speed with Std. tires)	Forward	1st	1.6 km/h (1.0 mph)		Low : 0 to 6.6 km/h (0 to 4.1 mph)	
		2nd	2.3 km/h (1.4 mph)			
		3rd	3.7 km/h (2.3 mph)			
		4th	5.5 km/h (3.4 mph)		Middle : 0 to 12.4 km/h (0 to 7.7 mph)	
		5th	7.7 km/h (4.8 mph)			
		6th	11.0 km/h (6.8 mph)			
		7th	17.8 km/h (11.1 mph)			
		8th	26.3 km/h (16.3 mph)			
	Reverse	1st	1.5 km/h (0.9 mph)		Low : 0 to 6.6 km/h (0 to 4.1 mph)	
		2nd	2.1 km/h (1.3 mph)			
		3rd	3.4 km/h (2.1 mph)		Middle : 0 to 12.4 km/h (0 to 7.7 mph)	
		4th	5.0 km/h (3.1 mph)			
		5th	7.1 km/h (4.4 mph)		High : 0 to 21.1 km/h (0 to 13.1 mph)	
		6th	10.0 km/h (6.2 mph)			
		7th	16.3 km/h (10.1 mph)			
8th		24.1 km/h (15.0 mph)				

SPECIFICATIONS (Continued)

Model		L3710		
		4WD	4WD-GST	4WD-HST
Maximum PTO power		23.5 kW (31.5 HP)*		22.4 kW (30.0 HP)*
Engine NET power		27.3 kW (36.6 HP)*		
Engine	Model	V1903- A		
	Type	Indirect injection, Vertical, Water-Cooled, 4-cycle diesel engine		
	Number of cylinders	4		
	Bore and stroke	80 x 92.4 mm (3.1 x 3.6 in.)		
	Total displacement	1857 cm ³ (113.3 cu.in.)		
	Rated revolution	43.3 r/s (2600 rpm)		
	Combustion chamber	Spherical type (E-TVCS)		
	Fuel injection pump	Bosch type mini pump (PFR4M)		
	Governor	Centrifugal ball mechanical governor		
	Injection nozzle	Throttle type		
	Injection timing	Before T.D.C. 0.314 rad (18°)		
	Injection order	1-3-4-2		
	Injection pressure	13.73 MPa (140 kgf/cm ² , 1991 psi)		
	Compression ratio	23 : 1		
	Lubricating system	Forced lubrication by trochoidal pump		
	Cooling system	Pressurized radiator, Forced circulation with water pump		
	Starting system	Electric starting with cell starter 12 V, 1.4 kW		
	Alternator	12 V, 480 W (40 AMPS)		
	Battery	12V, RC : 137 min, CCA : 447- Cold cranking Amps at -18 °C (- 0.4 °F)		
	Fuel	Diesel fuel No. 1 [below - 10 °C (14 °F)] Diesel fuel No. 2 [above - 10 °C (14 °F)]		
Lubricating oil	CC or CD (API grade)			
Weight (Dry)	206.5 kg (455 lbs)			
Capacities	Fuel tank	35.0 ℓ (9.2 U.S.gals., 7.7 Imp.gals.)		
	Engine crankcase	7.6 ℓ (8.0 U.S.qts., 6.7 Imp.qts.)		
	Engine coolant	7.5 ℓ (7.9 U.S.qts., 7.0 Imp.qts.)		
	Transmission case	39.0 ℓ (10.3 U.S.gals., 8.6 Imp.gals.)		
	Front axle case	5.5 ℓ (5.8 U.S.qts., 4.8 Imp.qts.)		
Dimensions (with Std. tires)	Overall length (without 3P)	3000 mm (118.1 in.)		
	Overall length (with 3P)	3210 mm (126.4 in.)		
	Overall width (minimum tread)	1425 mm (56.1 in.)		
	Overall height (Top of ROPS)	2120 mm (83.5 in.)		
	Overall height (Top of steering wheel)	1525 mm (60.0 in.)		
	Wheel base	1805 mm (71.1 in.)		
	Min. ground clearance (Under transmission)	335 mm (13.2 in.)		
	Tread	Front mm (in.)	1155 (45.5)	
Rear mm (in.)		1180 (46.5), 1200 (47.2), 1300 (51.2), 1450 (57.1), 1545 (60.8)		

Note : * Manufacturer's estimate

Model			L3710		
			4WD	4WD-GST	4WD-HST
Traveling system	Tire size (Std. tires)	Front	8.3 - 16		
		Rear	13.6 - 24		
	Clutch		Dry type single stage		
	Steering		Hydrostatic power steering		
	Transmission		Synchronized shuttle and synchronized transmission (8 forward)	Glide shift transmission (8 forward and 8 reverse speeds)	
	Brake	Traveling	Wet disc type		
		Parking	Connected with the traveling brake		
Differential		Bevel gear			
Hydraulic system	Hydraulic control system		Position control, Draft and Mixed control (if equipped)		
	Pump capacity (Max. flow rate)		Main pump 29.5 ℓ /min (7.8 GPM) Power steering pump 15.3 ℓ /min (4.0 GPM)		
	Three point hitch		SAE Category I		
	Maximum lifting capacity (24 in. behind lower link end)		1050 kg (2310 lbs)		
Rear PTO	PTO shaft		SAE 1-3/8, 6-splines (with overrunning clutch)		
	Revolution	Transmission PTO	1 speed : 9.0 r/s (540 rpm) / engine 40.8 r/s (2447 rpm)		—
		Independent PTO	1 speed : 9.0 r/s (540 rpm) / engine 41.3 r/s (2475 rpm)		1 speed : 9.0 r/s (540 rpm) / engine 40.6 r/s (2436 rpm)
Mid PTO	PTO shaft		USA No. 5 (KUBOTA 10-tooth) involute spline		
	Revolution	Transmission PTO	1 speed : 33.3 r/s (2000 rpm) / engine 40.1 r/s (2404 rpm)		—
		Independent PTO	1 speed : 33.3 r/s (2000 rpm) / engine 40.5 r/s (2432 rpm)		1 speed : 33.3 r/s (2000 rpm) / engine 39.9 r/s (2394 rpm)
Min. turning radius (with brake)			2.5 m (8.2 ft)		2.6 m (8.5 ft)
Traction system			Fixed drawbar or swing drawbar (if equipped)		
Weight (with ROPS)			1340 kg (2955 lbs)	1345 kg (2965 lbs)	1355 kg (2990 lbs)
Traveling speed (at rated engine speed with Std. tires)	Forward	1st	1.4 km/h (0.9 mph)		Low : 0 to 5.8 km/h (0 to 3.6 mph)
		2nd	2.0 km/h (1.2 mph)		
		3rd	3.2 km/h (2.0 mph)		
		4th	4.8 km/h (3.0 mph)		Middle : 0 to 10.8 km/h (0 to 6.7 mph)
		5th	6.8 km/h (4.2 mph)		
		6th	9.6 km/h (6.0 mph)		High : 0 to 23.1 km/h (0 to 14.4 mph)
		7th	15.6 km/h (9.7 mph)		
		8th	23.0 km/h (14.3 mph)		
	Reverse	1st	1.3 km/h (0.8 mph)		Low : 0 to 4.6 km/h (0 to 2.9 mph)
		2nd	1.8 km/h (1.1 mph)		
		3rd	3.0 km/h (1.9 mph)		Middle : 0 to 8.6 km/h (0 to 5.4 mph)
		4th	4.4 km/h (2.7 mph)		
		5th	6.2 km/h (3.9 mph)		High : 0 to 18.5 km/h (0 to 11.5 mph)
		6th	8.8 km/h (5.5 mph)		
		7th	14.3 km/h (8.9 mph)		
8th		21.1 km/h (13.1 mph)			

SPECIFICATIONS (Continued)













Model		L4310			
		2WD	4WD	4WD-GST	4WD-HST
Maximum PTO power		28.0 kW (37.5 HP)*			26.8 kW (36.0 HP)*
Engine NET power		32.1 kW (43.0 HP)*			
Engine	Model	V2203- A			
	Type	Indirect injection, Vertical, Water-Cooled, 4-cycle diesel engine			
	Number of cylinders	4			
	Bore and stroke	87 × 92.4 mm (3.4 × 3.6 in.)			
	Total displacement	2197 cm ³ (134.1 cu.in.)			
	Rated revolution	43.3 r/s (2600 rpm)			
	Combustion chamber	Spherical type (E-TVCS)			
	Fuel injection pump	Bosch type mini pump (PFR4M)			
	Governor	Centrifugal ball mechanical governor			
	Injection nozzle	Throttle type			
	Injection timing	Before T.D.C. 0.314 rad (18°)			
	Injection order	1-3-4-2			
	Injection pressure	13.73 MPa (140 kgf/cm ² , 1991 psi)			
	Compression ratio	23 : 1			
	Lubricating system	Forced lubrication by trochoidal pump			
	Cooling system	Pressurized radiator, Forced circulation with water pump			
	Starting system	Electric starting with cell starter 12 V, 1.4 kW			
	Alternator	12 V, 480 W (40 AMPS)			
	Battery	12V, RC : 137 min, CCA : 447- Cold cranking Amps at -18°C (-0.4°F)			
	Fuel	Diesel fuel No. 1 [below - 10 °C (14 °F)] Diesel fuel No. 2 [above - 10 °C (14 °F)]			
Lubricating oil	CC or CD (API grade)				
Weight (Dry)	206.5 kg (455 lbs)				
Capacities	Fuel tank	35.0 ℓ (9.2 U.S.gals., 7.7 Imp.gals.)			
	Engine crankcase	7.6 ℓ (8.0 U.S.qts., 6.7 Imp.qts.)			
	Engine coolant	7.5 ℓ (7.9 U.S.qts., 7.0 Imp.qts.)			
	Transmission case	39.0 ℓ (10.3 U.S.gals., 8.6 Imp.gals.)			
	Front axle case	—	5.5 ℓ (5.8 U.S.qts., 4.8 Imp.qts.)		
Dimensions (with Std. tires)	Overall length (without 3P)	3020 mm (118.9 in.)			
	Overall length (with 3P)	3230 mm (127.2 in.)			
	Overall width (minimum tread)	1585 mm (62.4 in.)			
	Overall height (Top of ROPS)	2145 mm (84.4 in.)			
	Overall height (Top of steering wheel)	1535 mm (60.4 in.)			
	Wheel base	1810 mm (71.3 in.)	1805 mm (71.1 in.)		
	Min. ground clearance (Under transmission)	370 mm (14.6 in.)			
	Tread	Front mm (in.)	1145 (45.1) 1245 (49.0) 1345 (53.0) 1445 (56.9)	1155 (45.5)	
Rear mm (in.)		1180 (46.5), 1200 (47.2), 1300 (51.2), 1450 (57.1), 1545 (60.8)			

Note : * Manufacturer's estimate

Model			L4310			
			2WD	4WD	4WD-GST	4WD-HST
Traveling system	Tire size (Std. tires)	Front	6.00 – 16	8.3 – 16		
		Rear	14.9 – 24			
	Clutch		Dry type single stage			
	Steering		Hydrostatic power steering			
	Transmission		Synchronized shuttle and synchronized transmission (8 forward and 8 reverse speeds)	Glide shift transmission (8 forward and 8 reverse speeds)		Hydrostatic transmission (3 speeds)
	Brake	Traveling	Wet disc type			
		Parking	Connected with the traveling brake			
Differential		Bevel gear				
Hydraulic system	Hydraulic control system		Position control, Draft and Mixed control (if equipped)			
	Pump capacity (Max. flow rate)		Main pump 29.5 ℓ/min (7.8 GPM) Power steering pump 15.3 ℓ/min (4.0 GPM)			
	Three point hitch		SAE Category I			
	Maximum lifting capacity (24 in. behind lower link end)		1050 kg (2310 lbs)			
Rear PTO	PTO shaft		SAE 1-3/8, 6-splines (with overrunning clutch)			
	Revolution	Transmission PTO	1 speed : 9.0 r/s (540 rpm) / engine 40.8 r/s (2447 rpm)			—
		Independent PTO	1 speed : 9.0 r/s (540 rpm) / engine 41.3 r/s (2475 rpm)			1 speed : 9.0 r/s (540 rpm) / engine 40.6 r/s (2436 rpm)
Min. turning radius (with brake)			2.5 m (8.2 ft)		2.6 m (8.5 ft)	
Traction system			Fixed drawbar or swing drawbar (if equipped)			
Weight (with ROPS)			1305 kg (2875 lbs)	1375 kg (3030 lbs)	1380 kg (3040 lbs)	1390 kg (3060 lbs)
Traveling speed (at rated engine speed with Std. tires)	Forward	1st	1.5 km/h (0.9 mph)			Low : 0 to 6.0 km/h (0 to 3.7 mph)
		2nd	2.1 km/h (1.3 mph)			
		3rd	3.3 km/h (2.1 mph)			Middle : 0 to 11.2 km/h (0 to 7.0 mph)
		4th	4.9 km/h (3.0 mph)			
		5th	7.0 km/h (4.3 mph)			High : 0 to 23.9 km/h (0 to 14.9 mph)
		6th	9.9 km/h (6.2 mph)			
		7th	16.1 km/h (10.0 mph)			
		8th	23.7 km/h (14.7 mph)			
	Reverse	1st	1.3 km/h (0.8 mph)			Low : 0 to 4.8 km/h (0 to 3.0 mph)
		2nd	1.9 km/h (1.2 mph)			
		3rd	3.1 km/h (1.9 mph)			Middle : 0 to 9.0 km/h (0 to 5.6 mph)
		4th	4.5 km/h (2.8 mph)			
		5th	6.4 km/h (4.0 mph)			High : 0 to 19.1 km/h (0 to 11.9 mph)
		6th	9.1 km/h (5.7 mph)			
		7th	14.7 km/h (9.1 mph)			
8th		21.8 km/h (13.5 mph)				

TRAVELING SPEEDS (WITH CREEP GEAR)

(at rated engine rpm)

Model				L3010		L3410		L3710		L4310	
Tire size (Rear)				11.2-24		12.4-24		13.6-24		14.9-24	
	Creep speed shift lever	Hi-Lo shift lever	Main shift lever	km/h	mph	km/h	mph	km/h	mph	km/h	mph
Forward		 (Low)	1	0.17	0.11	0.18	0.11	0.16	0.10	0.16	0.10
			2	0.24	0.15	0.26	0.16	0.22	0.14	0.23	0.14
			3	0.39	0.24	0.41	0.26	0.36	0.22	0.37	0.23
			4	0.58	0.36	0.61	0.38	0.53	0.33	0.55	0.34
		 (High)	1	0.82	0.51	0.87	0.54	0.76	0.48	0.78	0.49
			2	1.16	0.72	1.23	0.77	1.07	0.67	1.11	0.69
			3	1.88	1.17	1.99	1.24	1.74	1.09	1.80	1.13
			4	2.77	1.73	2.94	1.84	2.57	1.61	2.66	1.66
	 (Off)	 (Low)	1	1.51	0.94	1.61	1.01	1.41	0.88	1.45	0.91
			2	2.14	1.34	2.28	1.42	1.99	1.24	2.06	1.29
			3	3.48	2.18	3.69	2.31	3.23	2.02	3.34	2.09
			4	5.13	3.21	5.46	3.41	4.77	2.98	4.93	3.08
		 (High)	1	7.28	4.55	7.74	4.84	6.77	4.23	7.00	4.38
			2	10.31	6.44	10.95	6.84	9.58	5.99	9.90	6.19
			3	16.73	10.46	17.78	11.11	15.55	9.72	16.07	10.04
			4	24.71	15.44	26.26	16.41	22.96	14.35	23.74	14.84
Reverse		 (Low)	1	0.16	0.10	0.16	0.10	0.15	0.09	0.15	0.09
			2	0.22	0.14	0.24	0.15	0.20	0.13	0.21	0.13
			3	0.36	0.22	0.38	0.23	0.33	0.21	0.34	0.21
			4	0.53	0.33	0.56	0.35	0.49	0.30	0.50	0.32
		 (High)	1	0.75	0.47	0.80	0.50	0.70	0.44	0.71	0.45
			2	1.06	0.66	1.13	0.70	0.98	0.61	1.02	0.64
			3	1.72	1.08	1.82	1.14	1.59	1.00	1.65	1.03
			4	2.54	1.59	2.69	1.68	2.36	1.47	2.44	1.52
	 (Off)	 (Low)	1	1.38	0.87	1.48	0.92	1.29	0.81	1.33	0.83
			2	1.96	1.23	2.09	1.31	1.82	1.14	1.89	1.18
			3	3.19	1.99	3.38	2.11	2.96	1.85	3.06	1.91
			4	4.70	2.94	5.00	3.13	4.37	2.73	4.52	2.82
		 (High)	1	6.67	4.17	7.09	4.43	6.21	3.88	6.42	4.01
			2	9.45	5.91	10.04	6.27	8.78	5.49	9.07	5.67
			3	15.33	9.58	16.30	10.19	14.25	8.91	14.73	9.21
			4	22.65	14.16	24.07	15.04	21.05	13.15	21.76	13.60

[HST Type]

Model		L3010		L3410		L3710		L4310	
Tire size (Rear)		12.4-24		12.4-24		13.6-24		14.9-24	
Forward	Hi	0 to 6.6	0 to 4.1	0 to 6.6	0 to 4.1	0 to 5.8	0 to 3.6	0 to 6.0	0 to 3.7
	Mi	0 to 12.4	0 to 7.7	0 to 12.4	0 to 7.7	0 to 10.8	0 to 6.7	0 to 11.2	0 to 7.0
	Lo	0 to 26.4	0 to 16.4	0 to 26.4	0 to 16.4	0 to 23.1	0 to 14.4	0 to 23.9	0 to 14.9
Reverse	Hi	0 to 6.6	0 to 4.1	0 to 6.6	0 to 4.1	0 to 4.6	0 to 2.9	0 to 4.8	0 to 3.0
	Mi	0 to 12.4	0 to 7.7	0 to 12.4	0 to 7.7	0 to 8.6	0 to 5.4	0 to 9.0	0 to 5.6
	Lo	0 to 21.1	0 to 13.1	0 to 21.1	0 to 13.1	0 to 18.5	0 to 11.5	0 to 19.1	0 to 11.9

DIMENSIONS

Unit : mm (in.)

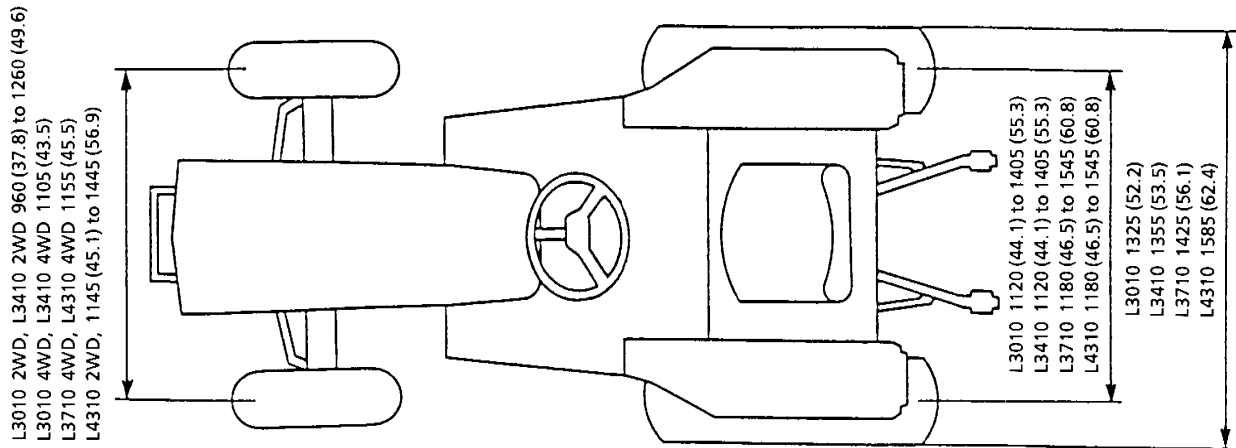

B161F003

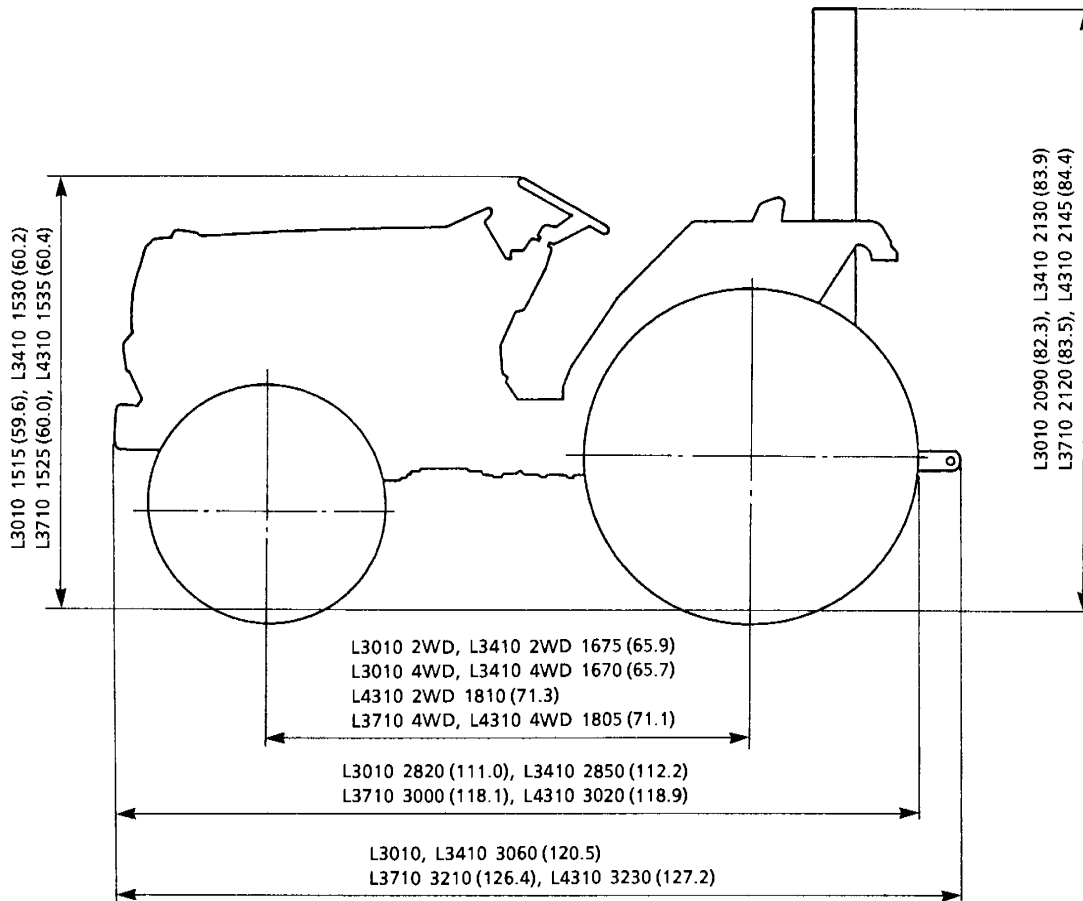

B161F004

CONTENTS

[1] FEATURES	G-1
[2] TRACTOR IDENTIFICATION	G-2
[3] GENERAL PRECAUTIONS	G-3
[4] HANDLING PRECAUTIONS FOR ELECTRICAL PARTS AND WIRING	G-4
[5] LUBRICANTS, FUEL AND COOLING WATER	G-8
[6] TIGHTENING TORQUES (GENERAL USE SCREWS, BOLTS AND NUTS)	G-9
[7] MAINTENANCE CHECK LIST	G-10
[8] CHECK AND MAINTENANCE	G-11
(1) Daily Check	G-11
(2) Check Points of Initial 50 Hours	G-12
(3) Check Points of Every 50 Hours	G-14
(4) Check Points of Every 100 Hours	G-17
(5) Check Points of Every 200 Hours	G-18
(6) Check Points of Every 400 Hours	G-20
(7) Check Points of Every 800 Hours	G-21
(8) Check Points of Every 1 Year	G-22
(9) Check Points of Every 2 Years	G-22
(10) Others	G-24
[9] SPECIAL TOOLS	G-25
[10] TIRES	G-35
(1) Types of Tire	G-35
(2) Tread Adjustment	G-36
(2)-1 Front Wheels	G-36
(2)-2 Rear Wheels	G-37
(3) Wheel Hub	G-38
(4) Tire Pressure	G-39
(5) Tire Liquid Injection	G-40
[11] SPECIFICATIONS OF IMPLEMENT LIMITATIONS	G-43

[1] FEATURES

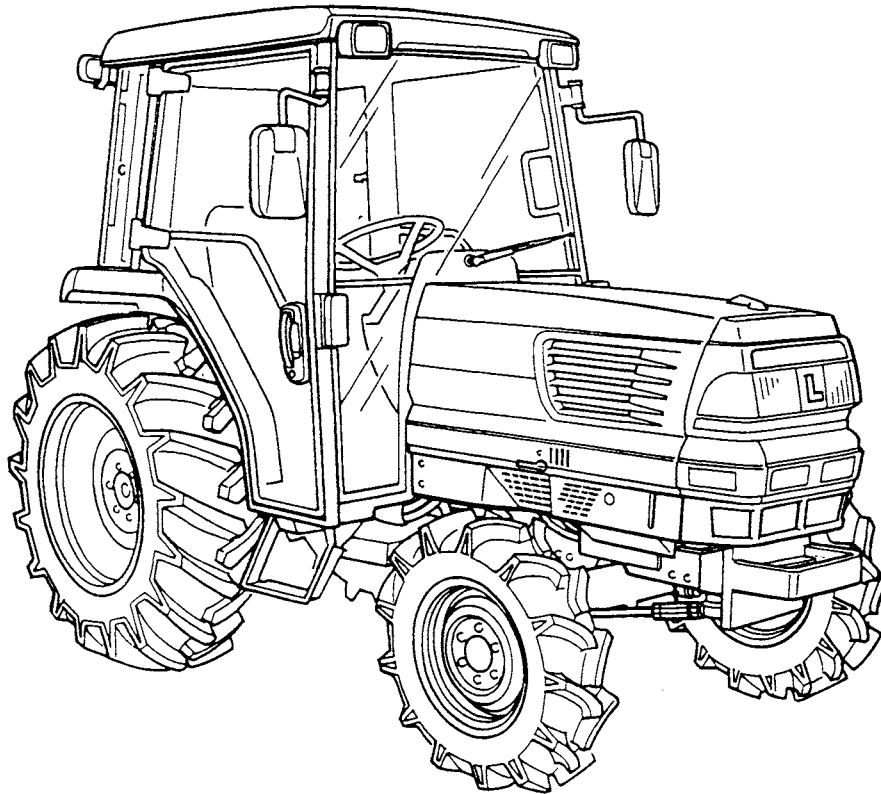

12190F00870

L3010, L3410, L3710 and L4310 tractors have the unique KUBOTA E-TVCS (Three Vortex Combustion System) Diesel Engine that delivers a more dynamic output and a greater torque with cleaner emissions.

The drive mechanisms are either Hydrostatic Transmission (HST), the GST (Glide Shift Transmission) or the Manual Transmission which incorporates the Synchro-Shuttle and the Full-Synchro Main Transmission. The some models are available CABIN specification. The comfortable integral cabin by KUBOTA.

Other distinctive features which contribute to making tractors in this series outperform all other tractors in the same class in comfort, durability, maneuverability, mobility, and ease of operation include the hydraulically actuated Independent PTO, the large-capacity Clutch, the large lift capacity of the 3-Point Hitch, Hydrostatic Power Steering, the Full-Floating Type Flat Deck, and the Hanging-Type Pedals.

[2] TRACTOR IDENTIFICATION

When contacting your local KUBOTA distributor, always specify engine serial number, tractor serial number and hourmeter reading.

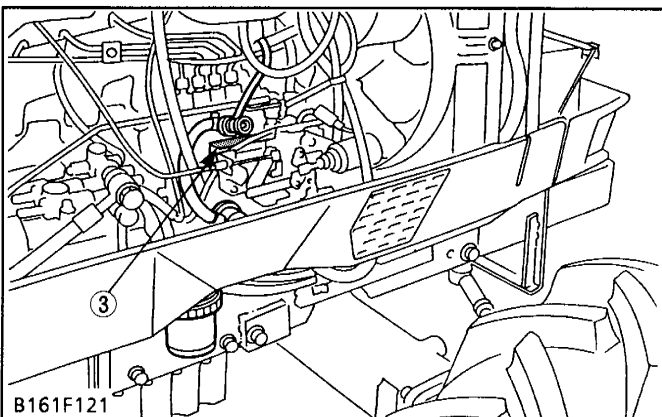
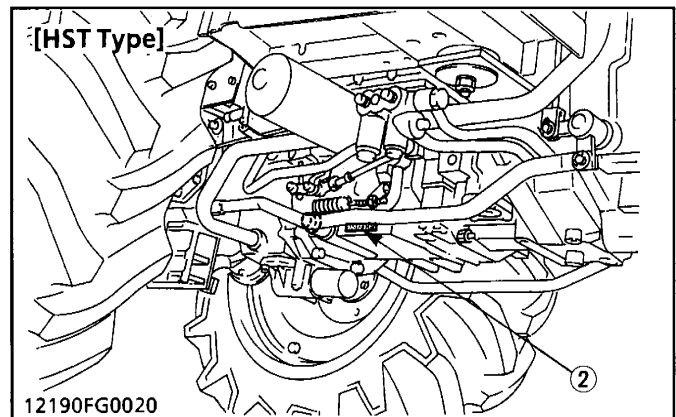
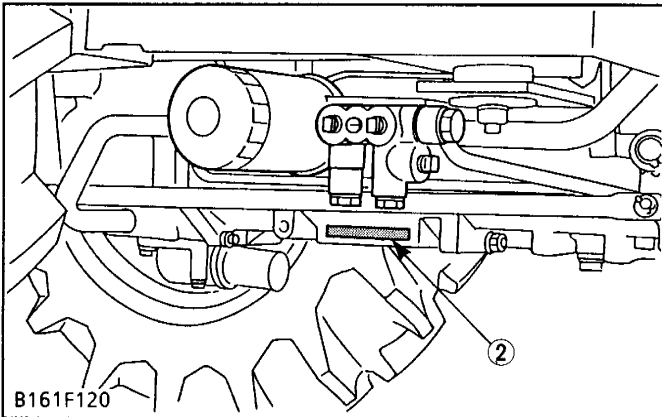
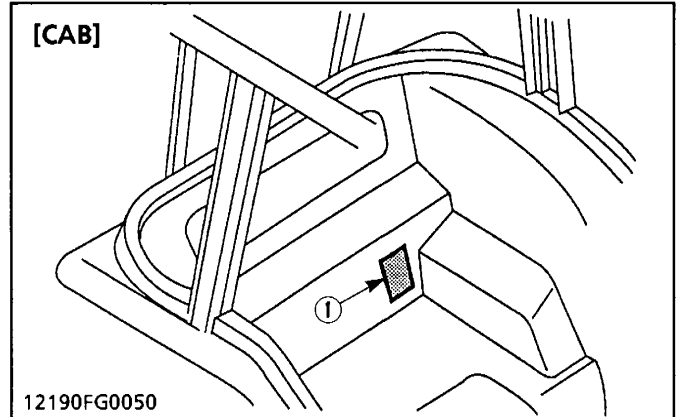
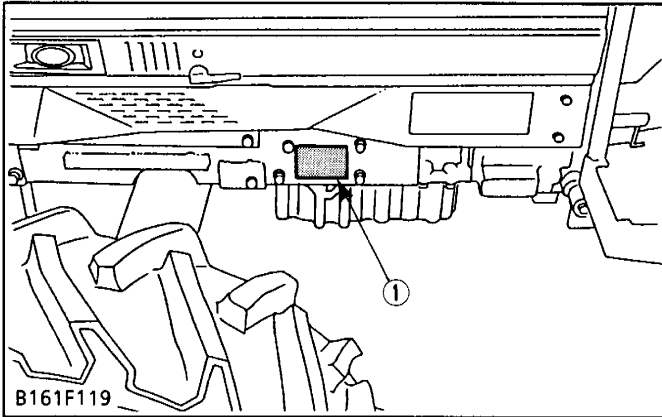

- (1) Tractor Identification Plate
- (2) Tractor Serial Number
- (3) Engine Serial Number
- (4) Hour Meter
- (5) Cabin Identification Plate
Cabin Serial Number

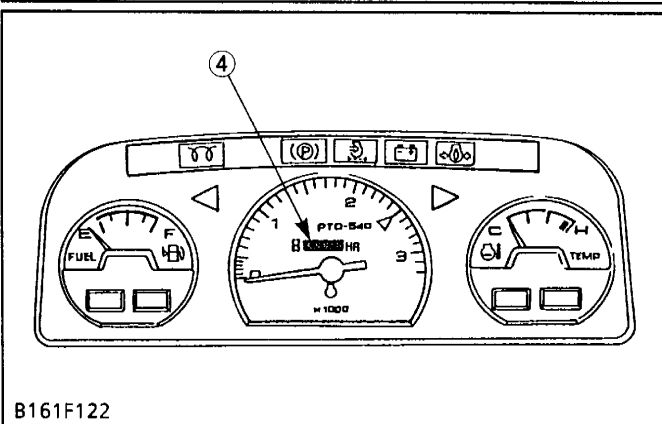

[3] GENERAL PRECAUTIONS

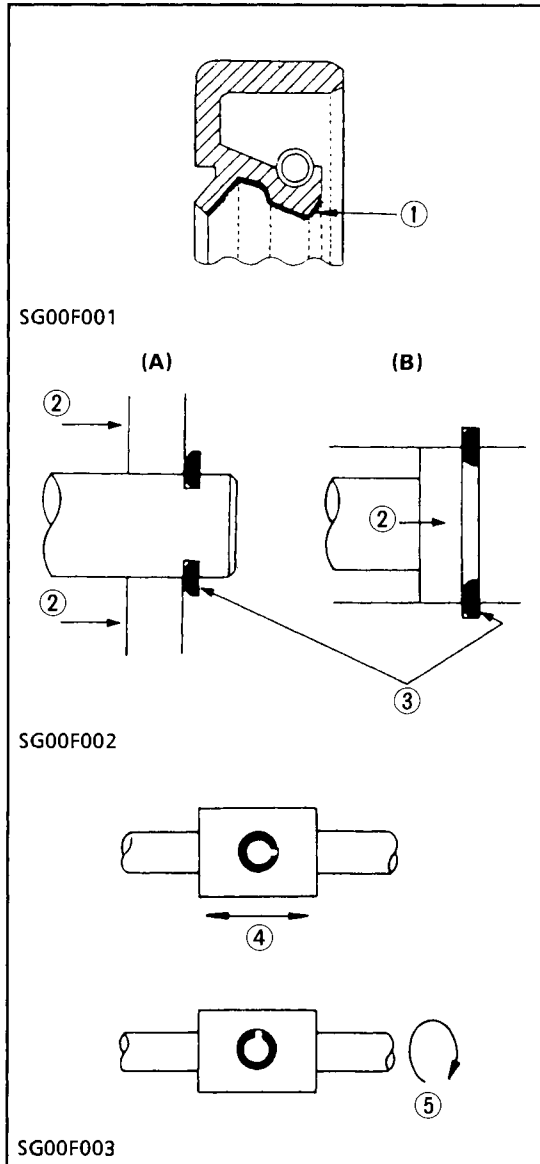

- During disassembly, carefully arrange removed parts in a clean area to prevent confusion later. Bolts and nuts should be installed in their original position to prevent reassembly errors.
- When special tools are required, use KUBOTA genuine special tools. Special tools which are not frequently used should be made according to the drawings provided.
- Before disassembling or servicing electrical wires, always disconnect the ground cable from the battery first.
- Remove oil and dirt from parts before measuring.
- Use only KUBOTA genuine parts for parts replacement to maintain tractor performance and to assure safety.
- Gaskets and O-rings must be replaced during reassembly. Apply grease to new O-rings or oil seals before assembling. See the figure left side.
- When reassembling external snap rings or internal snap rings, they must be positioned so that sharp edge faces against the direction from which a force is applied. See the figure left side.
- When inserting spring pins, their splits must face the direction from which a force is applied. See the figure left side.
- To prevent damage to the hydraulic system, use only specified fluid or equivalent.

- (1) Grease
 - (2) Force
 - (3) Sharp Edge
 - (4) Axial Force
 - (5) Rotating Movement
- [A] External Snap Ring
 - [B] Internal Snap Ring

[4] HANDLING PRECAUTIONS FOR ELECTRICAL PARTS AND WIRING

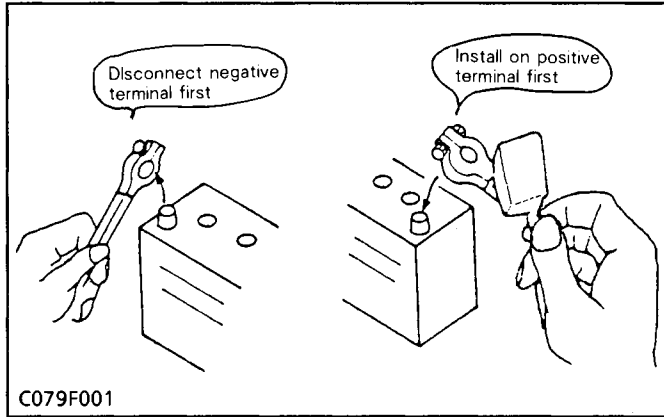

C079F001

To ensure safety and prevent damage to the machine and surrounding equipment, heed the following precautions in handling electrical parts and wiring.

■ IMPORTANT

- Check electrical wiring for damage and loosened connection every year. To this end, educate the customer to do his or her own check and at the same time recommend the dealer to perform periodic check for a fee.
- Do not attempt to modify or remodel any electrical parts and wiring.
- When removing the battery cord, disconnect the negative wire first. When installing the battery cord, connect the positive wire first.

■ Wiring

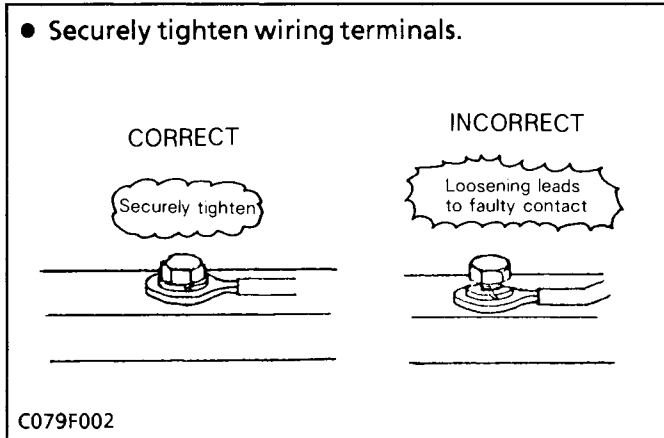

C079F002

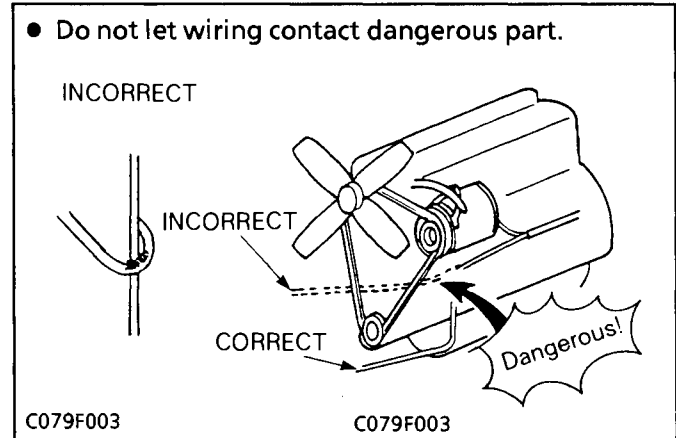

C079F003

C079F003

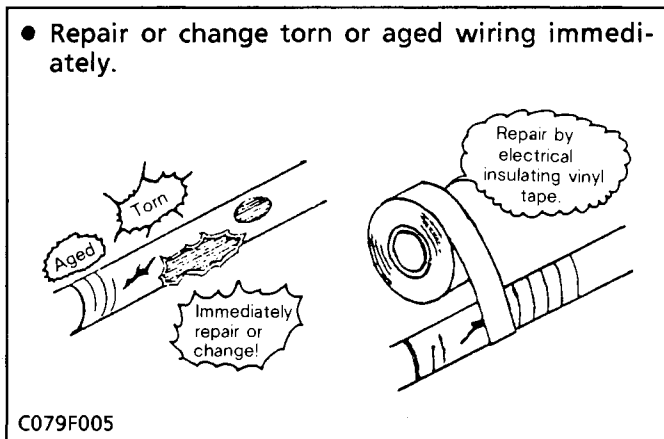

C079F005

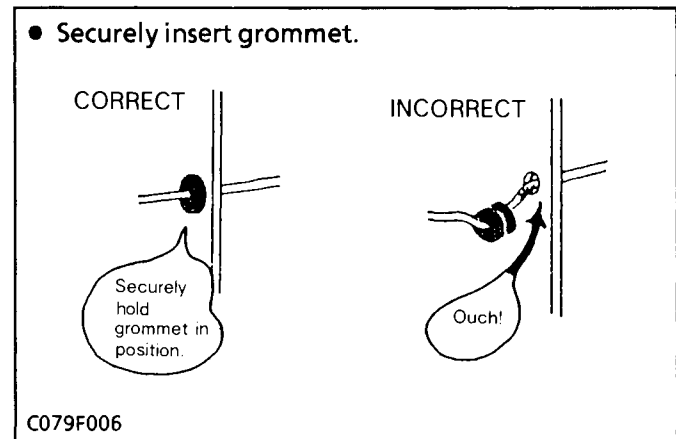

C079F006

- Securely clamp, being careful not to damage wiring.

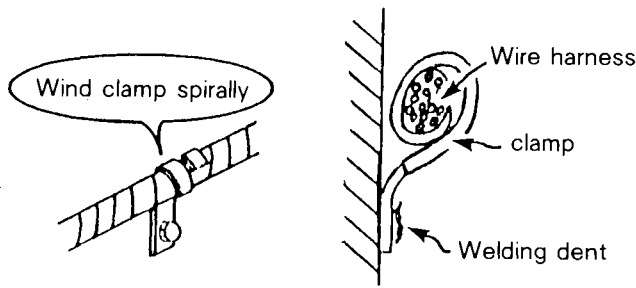

C079F007

C079F008

- Clamp wiring so that there is no twist, unnecessary sag, or excessive tension, except for movable part, where sag may be required.

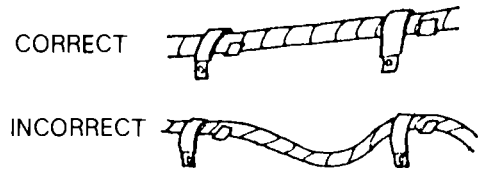

C079F009

- In installing a part, take care not to get wiring caught by it.

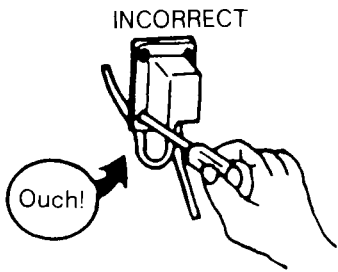

C079F010

- After installing wiring, check protection of terminals and clamped condition of wiring, only then connect battery.

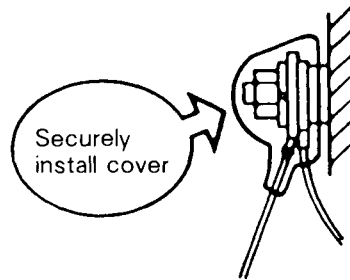

C079F011

Battery

Take care not to confuse positive and negative terminals.

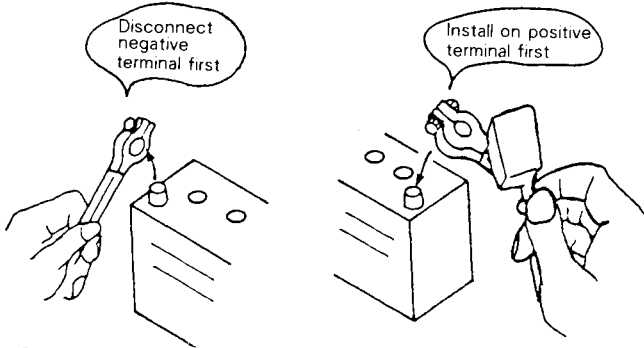

C079F001

- When removing battery cord, disconnect negative wire first. When installing battery cord, check for polarity and connect positive wire first.
- Do not install any battery with capacity other than is specified (Ah).
- After connecting cord to battery terminals, apply grease to them and securely install terminal covers on them.
- Do not allow dirt and dust to collect on battery.

CAUTION

- Take care not to let battery liquid spill on your skin and clothes. If contaminated, wash it off with water immediately.
- Before recharging the battery, remove it from the machine.
- Before recharging, remove cell caps.

CAUTION

- Do recharging in a well-ventilated place where there is no open flame nearby, as hydrogen gas and oxygen are formed.

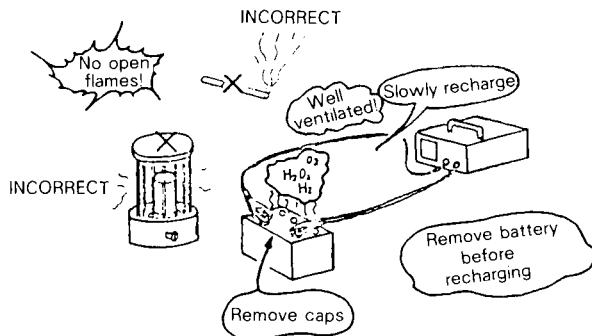

C079F013

■ Fuse

- Use fuses with specified capacity.
- Never use steel or copper wire in place of fuse.

Use the fuses with specified capacity

Neither too large or small capacity fuse is acceptable!

Do not substitute copper or steel wire!

C079F014

- Do not install working light, radio set, etc. on machine which is not provided with reserve power supply.
- Do not install accessories if fuse capacity of reserve power supply is exceeded.

Use reserve power supply for working light

It is dangerous to modify or remodel as you please

C079F015

■ Connector

- For connector with lock, push lock to separate.

Unlock

Push lock to remove

C079F016

- In separating connectors, do not pull wire harnesses.

CORRECT

Hold connector bodies to separate

INCORRECT

Ouch!

Getting torn off

C079F017

- Use sandpaper to remove rust from terminals.
- Repair deformed terminal. Make certain there is no terminal being exposed or displaced.

Use sandpaper remove rust from terminals.

No bending!

No displaced or exposed terminal

C079F018

C079F019

- Make certain that there is no female connector being too open.

CORRECT

INCORRECT

C079F020

CORRECT

INCORRECT

C079F021

- Make certain plastic cover is large enough to cover whole connector.

CORRECT

Plastic cover large enough to cover entire connector

INCORRECT

No coming off

No tear off

C079F028

Please click here and go
back to our website.

BUY NOW

**Then Instant Download the
Complete Manual.**

Thank you very much!